

DESCRIPTION

The DigiFlow DFS series flow meters provide low flow sensing capabilities in a wide range of OEM and end-user applications. Utilizing a rotor which, through use of an infrared beam, generates a digital signal, the DigiFlow concept offers high accuracy, low cost, and a flexible design to meet customer requirements. In either flow controlled, or monitoring applications, the DFS series meters can measure flow rates and total quantities.



Model DFS-2

DESIGN FEATURES

- 2 ranges from 0.07 – 25 litres/minute (.02 – 6.6 GPM)
- quantity measurements as small as 0.1 ml.
- accuracy within $\pm 0.5\%$ or better
- operational pressures up to 70 bar (1,000 PSIG)
- wetted surfaces of high quality polymers
- housing of high quality polymers or machined metal
- low pressure drops
- friction free fluid bearings yielding long life
- compatible with most acids and bases
- turn down ratios of up to 64 : 1
- mount in any position without flow straighteners
- infrared signal pick-up
- resolution of up to 65,000 pulses/litre (246,000/gallon)

SYSTEMS & APPLICATIONS

Connected to a basic counter, the DFS meter can monitor flow rates and/or total quantities. In conjunction with a stand-alone controller or interfaced with process control or general purpose computers, the DFS is an integral part of flow controlled processes. In end-use, or in OEM applications, including those requiring disposable components, the DFS is a key part in a systems approach to a wide range of monitoring and controlling applications including:

- dosing of chemicals into main stream flows for agricultural, water treatment, and other requirements
- medical/pharmaceutical equipment
- additive injection in chemical processes
- monitoring/controlling fuel flows
- monitoring pulse feed pump flows
- beverage dispensing

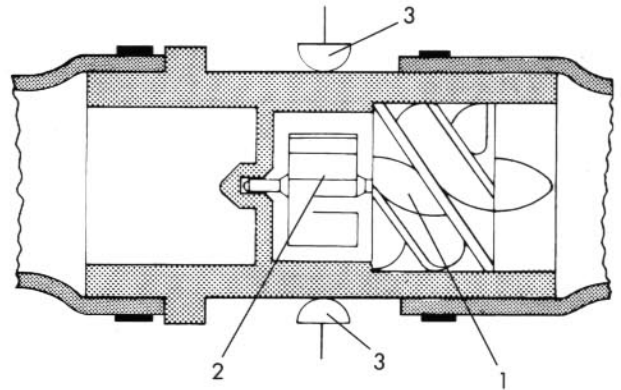

PRINCIPLE OF OPERATION

The fluid flows through the meter, first passing the fixed worm (1) imparting a spiral flow which, in turn, spins the rotor (2) on a virtually friction free bearing. The rotor blades interrupt an infrared beam (3), thus generating a square wave digital output signal.

The rotor is the only moving part. Due to its light weight and the helical pattern of the fluid flow, the rotor has a minimal response time, thus resulting in a very high level of resolution and exceptional accuracy, linearity, and repeatability throughout flow and viscosity ranges.

DFS meters can be mounted in any position and do not require flow straighteners or other specialized installations. Meters are available with hose/barb, threaded and sanitary fittings, as well as with disposable rotor assemblies.

SPECIFICATIONS

	DFS-2	DFS-3
(Data based on water)		
Media	liquids	liquids
Flow Range – Linear	0.07– 4.5 L/m (.02–1.2GPM)	0.66 – 25 L/m (.17– 6.6 GPM)
Turndown Ratio	64:1	38:1
Accuracy	±0.5% (of actual flow reading)	±0.5% (of actual flow reading)
Linearity Deviation	0.5%	0.5%
Repeatability	<0.15%	<0.10%
Resolution Pulses (K-factor)	65,000 pulses/L (246,000 pulses/Gal.)	4,400/L (16,650 pulses/Gal.)
Temperature Range		
Operational – Media	–20 to + 85°C (–4 to +185°F)	–20 to + 85°C (–4 to +185°F)
Static	–20 to +130°C (–4 to +266°F)	–20 to +130°C (–4 to +266°F)
Viscosity Range	0.8 – 10 mm ² /s (0.8 – 10 cSt)	0.8 – 15 mm ² /s (0.8 – 15 cSt)
Operational Pressure – Max	50 bar (710 PSIG)*	50 bar (710 PSIG)
Pressure Drop	0.2 bar @ 1 L/m (2.9 PSI @ .25 GPM)	0.2 bar @ 5 L/m (2.9 PSI @ 1.3 GPM)
Power Supply	5 VDC, 12 – 36 mAmp [†]	5 VDC, 12 – 36 mAmp [†]
Output Signal	Square Wave	Square Wave
Materials– Rotor Assy	PVDF–Solef [®] (Polyvinylidene fluoride)	PVDF–Solef [®]
– Housing	PVDF–Solef [®]	PVDF–Solef [®]
– O-rings	Fluorine Rubber (Viton [®])	Viton [®]
Electrical Lead	4 meters (157") in length	4 meters (157") in length
Dimensions – Length	63.3 mm (2.5")	74 mm (2.91")
– Max Diameter	21.0 mm (0.83")	44 mm (1.73")
Connections	7 mm (9/32") hose barb fitting	3/8" male NPT or 3/8" male BSP

OPTIONS

Materials– Housing	Aluminum, 316L SS, other moldable polymers	
– O-rings	EPDM (Ethylene Propylene Rubber), or other	
Output Signal	Converter to 4 – 20 mA, 1 – 5V. analog signal available	
Power Supply	12–24 VDC accommodated externally, or internal modification for OEM orders	
Electrical Lead	Other lengths available/ or terminal box	
Connections	Male 1/4" NPT or 1/4" BSP	Male 1/4" NPT or 1/4" BSP
	1/2" Sanitary Tri-clamp	3/4" Sanitary Tri-clamp

* For 1/4" NPT/BSP DFS-2 70 bar (1000 PSIG).

[†] Units set up internally for 5 volts. Other voltages accommodated with external resistor, or internal modification with volume orders.

Solef[®] is a registered tradename of Solvay S.A.
Viton[®] is a registered tradename of E.I. DuPont, Inc.

DigiFlow Systems B.V.

Postbus 46
6580 AA Malden
The Netherlands

Ph: 31-243-582929
Fx: 31-243-586060
<http://www.avd.nl/digiflow>

DigiFlow Systems

781 Clifton Blvd
Mansfield, OH 44907
USA

Ph: (419) 756-1746
Fx: (419) 756-0643

Represented By: